

# THE 20-TON (18180 kg) ARVA MC400H

# MC400H-4040LP 20-TON CRANE HEAVY LIFT PACKAGE

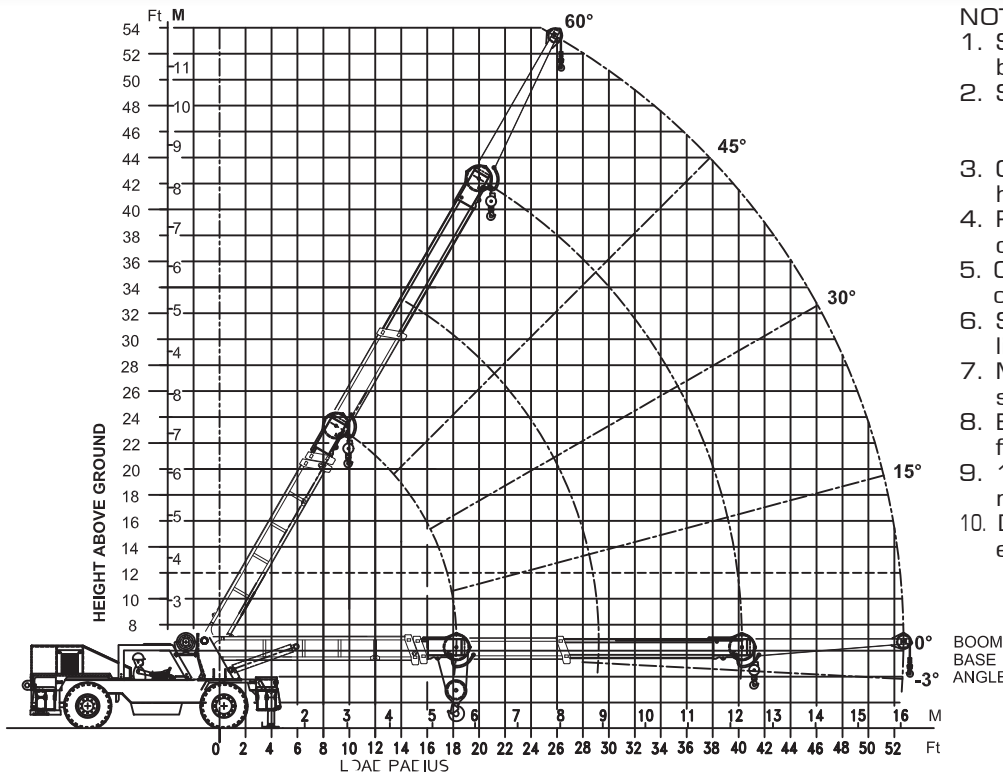

### NOTES:

1. Stability governs capacity below dotted line.
2. Stability percent:  
on outriggers = 85%,  
on tires = 75%
3. Capacities shown include cable, hook block, rigging and load.
4. Review operators manual before operating crane.
5. Capacity available on outriggers on tires within 278° swing stops.
6. Single part line capacity limited to 22,000 lbs.
7. Maximum pick & carry travel speed 2.5 mph.
8. Boom to be centered over front for pick & carry.
9. 12 ft. Swingaway extension has maximum capacity of 2000 lbs.
10. Diagram may show optional equipment.

### BOOM LENGTH

18'- 0" to 40'-0"

5.48 M to 12.19 M

WITH SWINGAWAY  
EXT'N 12'-0" (3.66 M)

LOAD RADIUS Ft. M	OUTRIGGER				ON TIRE				PICK & CARRY OVER FRONT (7+8)		PICK & CARRY SMOOTH FLOOR (7+8)	
	OVER FRONT		360° (5)		OVER FRONT		360° (5)		LBS	KGS	LBS	KGS
	LBS	KGS	LBS	KGS	LBS	KGS	LBS	KGS	LBS	KGS	LBS	KGS
10 3.1	40000	18180	40000	18180	17700	8070	11250	5110	13100	5950	16300	7430
12 3.6	35200	16000	35200	16000	14350	6520	8850	4020	11650	5290	14350	6520
14 4.2	31050	14110	31050	14110	11900	5400	7150	3250	10450	4750	11900	5400
16 4.8	25600	11630	25600	11630	10050	4570	5900	2680	9400	4270	10050	4570
18 5.5	21600	9820	21600	9820	8650	3930	4950	2250	8500	3860	8650	3930
20 6.1	18600	8450	18600	8450	7500	3410	4150	1880	7500	3410	7500	3410
22 6.7	16450	7470	16450	7470	6650	3020	3550	1610	6650	3020	6650	3020
24 7.3	14500	6590	14400	6540	5900	2680	3000	1360	5900	2680	5900	2680
26 7.9	12900	5860	12500	5680	5200	2360	2550	1160	5200	2360	5200	2360
28 8.5	11700	5320	11100	5040	4750	2160	2200	1000	4750	2160	4750	2160
30 9.1	10600	4820	9850	4470	4250	1930	1900	860	4250	1930	4250	1930
34 10.3	8900	4040	8000	3630	3500	1590	1350	610	3500	1590	3500	1590
38 11.5	7550	3430	6650	3020	2900	1310	950	430	2900	1320	2900	1320

Constant improvement and engineering progress make it necessary for ARVA Industries Inc. to reserve the right to make specifications and equipment changes without notice.

Rugged, mining cranes  
since 1979



43 Gaylord Rd.,  
St. Thomas, ON, N5P 3R9  
tel: (519) 637-1855  
fax: (519) 637-1848  
email: sales@arvaindustries.com  
web: www.arvaindustries.com



THE 20-TON (18180 kg)

# ARVA MC400H FEATURES

**A true underground mining crane!**

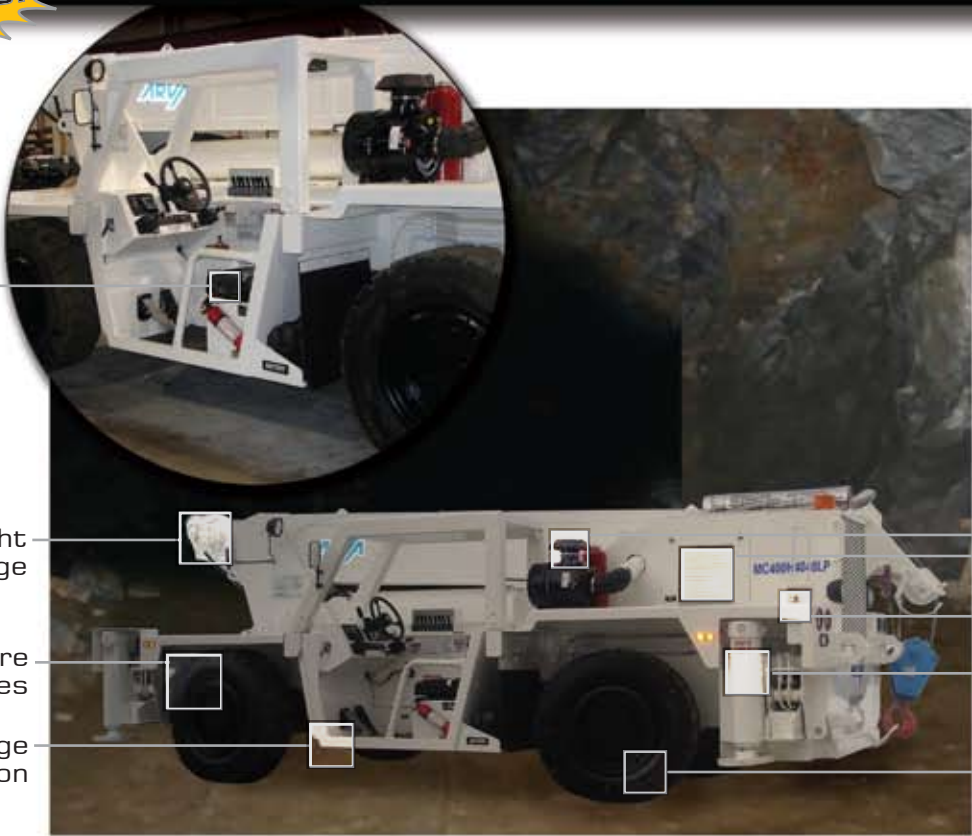

Suspension seat

Boom light package

Soft core filled tires

Undercarriage protection

Gradability: more than adequate capabilities

Marine grade wiring throughout

Forward mounted boom reduces radius & boom length

Single line pull 22,000 lbs

Internal wet disc brakes  
Brakes comply with CAN/CSA-M454.3-M90

Air Cleaner  
Easy access panels for ease of maintenance  
Fire suppression

Down & out outriggers with guarded rods

4 wheel drive, 2 wheel steer

Enhanced boom reach

Pick and carry: 16 300 lbs (smooth surface)

-3 to +60 degree boom angle

Length: 238.5 in  
Width: 100 in  
Height: 88 in

278 degree boom rotation

Lifting capacities comply with SAE J-765 and J-1257 as applicable



Independent manual outrigger controls

Pilot operated boom controls

Fire suppression system

Cummins Tier III engine  
CANMET, MSHA and EPA certified

FOPS/ROPS cab